

# Panasonic

## Colour CCTV Cameras Operating Instructions

Model No. **WV-CP240**  
**WV-CP242**  
**WV-CP244**

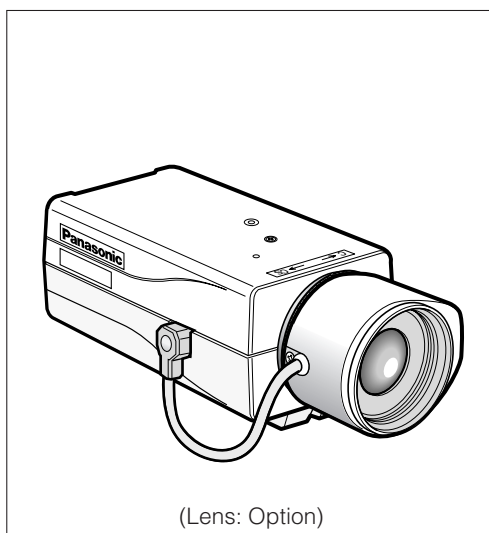

(Lens: Option)

Before attempting to connect or operate this product, please read these instructions carefully and save this manual for future use.

N0601-2043 V8QA5816CN Printed in Japan  
N 19

### FOR YOUR SAFETY PLEASE READ THE FOLLOWING TEXT CAREFULLY.

**WARNING: This apparatus must be earthed.**

#### IMPORTANT

The wires in this mains lead are coloured in accordance with the following code.

Green-and-yellow:	Earth
Blue:	Neutral
Brown:	Live

As the colours of the wire in the mains lead of this appliance may not correspond with the coloured markings identifying the terminals in your plug, proceed as follows.

The wire which is coloured **green-and-yellow** must be connected to the terminal in the plug which is marked with the letter **E** or by the earth symbol  $\perp$  or coloured **green** or **green-and-yellow**.

The wire which is coloured **blue** must be connected to the terminal in the plug which is marked with the letter **N** or coloured **black**.

The wire which is coloured **brown** must be connected to the terminal in the plug which is marked with the letter **L** or coloured **red**.

We declare under our sole responsibility that the product to which this declaration relates is in conformity with the standards or other normative documents following the provisions of Directives EEC/73/23 and EEC/89/336.

Wij verklaren als enige aansprakelijke, dat het product waarop deze verklaring betrekking heeft, voldoet aan de volgende normen of andere normatieve documenten, overeenkomstig de bepalingen van Richtlijnen 73/23/EEC en 89/336/EEC.

Vi erklærer os eneansvarlige for, at dette produkt, som denne deklaration omhandler, er i overensstemmelse med standarder eller andre normative dokumenter i følge bestemmelserne i direktivene 73/23/EEC og 89/336/EEC.

Vi deklarerar härmed vårt fulla ansvar för att den produkt till vilken denna deklaration hänvisar är i överensstämmelse med standarddokument, eller andra normativa dokument som framställs i EEC-direktiv nr. 73/23 och 89/336.

Ilmoitamme yksinomaisella vastuullamme, että tuote, jota tämä ilmoitus koskee, noudattaa seuraavia standardeja tai muita ohjeellisia asiakirjoja, jotka noudattavat direktiivien 73/23/EEC ja 89/336/EEC sääöksiä.

Vi erklærer oss alene ansvarlige for at produktet som denne erklæringen gjelder for, er i overensstemmelse med følgende normer eller andre normgivende dokumenter som følger bestemmelsene i direktivene 73/23/EEC og 89/336/EEC.

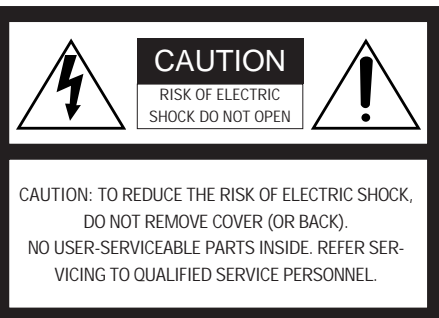

The lightning flash with arrowhead symbol, within an equilateral triangle, is intended to alert the user to the presence of uninsulated "dangerous voltage" within the product's enclosure that may be of sufficient magnitude to constitute a risk of electric shock to persons.

The exclamation point within an equilateral triangle is intended to alert the user to the presence of important operating and maintenance (servicing) instructions in the literature accompanying the appliance.

The serial number of this product may be found on the bottom of the unit. You should note the serial number of this unit in the space provided and retain this instruction as a permanent record of your purchase to aid identification in the event of theft.

Model No. \_\_\_\_\_  
Serial No. \_\_\_\_\_

**WARNING:**  
To reduce the risk of fire or electric shock, do not expose this appliance to rain or moisture.

## PREFACE

Panasonic's WV-CP240/CP242/CP244 series digital signal processing colour CCD cameras introduce a new level of high picture quality and high resolution through the use of a 1/3-inch interline

transfer CCD image sensor having 752 horizontal pixels (picture elements), and digital signal processing LSI's. This model offers cutting-edge technology for advanced video surveillance.

## FEATURES

- The following functions are built in.
  - (1) Auto Light Control (ALC)/Electronic Light Control (ELC)
  - (2) Automatic Gain Control (AGC) +15 dB and Automatic Tracing White Balance (ATW)
  - (3) Camera synchronization mode selectable between internal (INT), Line-locked (LL) for WV-CP240 and WV-CP244 and Multiplexed Vertical Drive (VD2).
- Minimum illumination of 0.6 lx (0.06 foot-candle) at F0.75 (equivalent to 2.0 lx (0.2 foot-candle) at F1.4)
- Signal-to-noise ratio of 50 dB (Equivalent to AGC Off)
- Horizontal resolution of 480 lines
- Auto iris lens control selectable between video signal and DC power supply.

## PRECAUTIONS

- Do not attempt to disassemble the camera.**  
To prevent electric shock, do not remove screws or covers.  
There are no user serviceable parts inside. Ask a qualified service person for servicing.
- Handle the camera with care.**  
Do not abuse the camera. Avoid striking, shaking, etc. The camera could be damaged by improper handling or storage.
- Do not expose the camera to rain or moisture, or try to operate it in wet areas.**  
Turn the power off immediately and ask a qualified service person for servicing. Moisture can damage the camera and also create the danger of electric shock.
- Do not use strong or abrasive detergents when cleaning the camera body.**  
Use a dry cloth to clean the camera when dirty.  
In case the dirt is hard to remove, use a mild detergent and wipe gently. Afterwards, wipe off the remained part of the detergent in it with a dry cloth.
- Clean the CCD faceplate with care.**  
Do not clean the CCD with strong or abrasive detergents. Use lens tissue or a cotton tipped applicator and ethanol.
- Never face the camera towards the sun.**  
Do not aim the camera at bright objects. Whether the camera is in use or not, never aim it at the sun or other extremely bright objects. Otherwise, blooming or smear may be caused.
- Do not operate the camera beyond the specified temperature, humidity or power source ratings.**  
Use the camera under conditions where temperature is between -10°C - +50°C (14°F - 122°F), and humidity is below 90 %. The input power source is 220 V - 240 V AC 50 Hz for WV-CP240, 12 V DC for WV-CP242, and 24 V AC 50 Hz for WV-CP244.

## MAJOR OPERATING CONTROLS AND THEIR FUNCTIONS

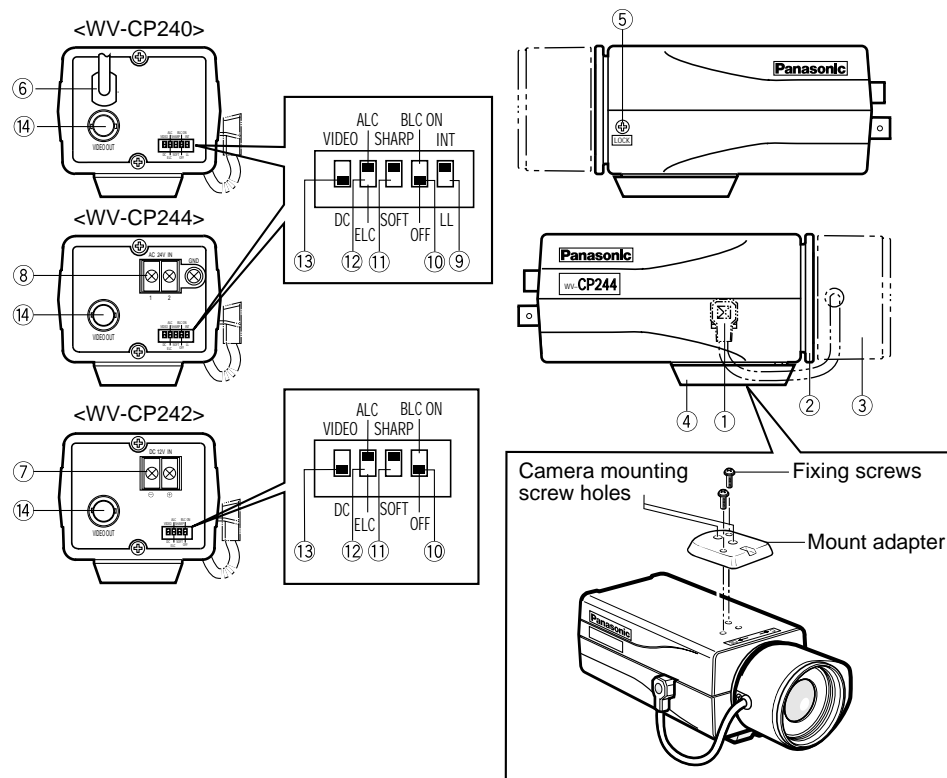

- Auto Iris Lens Connector**  
Supplies power and control signals to an auto iris lens (not supplied).
- Flange-back Adjusting Ring**  
This ring adjusts the back-focal distance or picture focus. Rotate this ring clockwise for a C-mount lens or counterclockwise for a CS-mount lens.
- Lens (option)**
- Mount Adapter**  
The camera mounting screw hole is for mounting the camera onto a mounting bracket. The camera is originally designed to be mounted from the bottom, however, a top-mounting type is also available. To mount from the top, remove the mount adapter from the bottom of the camera by removing two fixing screws. Attach the mount adapter to the top as shown in the diagram, then mount the camera on the mounting bracket. Make sure that two original screws are used when mounting the mount adapter; longer type screws may damage inner components, too shorter type screws may cause the camera drop.
- Focus Fixing Screw**
- Power Cord (only for WV-CP240)**  
Connect this power cord to an electrical outlet of 220 V - 240 V AC 50 Hz.
- DC 12 V Input Terminal [DC 12V IN (only for WV-CP242)]**  
This terminal is for connecting the 12 V DC power supply cord.
- AC 24 V Input Terminal [AC 24V IN (only for WV-CP244)]**  
This terminal is for connecting the 24 V AC 50 Hz power supply cord.
- Synchronization Mode Selector [INT, LL (only for WV-CP240 and WV-CP244)]**  
Selects the camera synchronization mode as either internal sync mode (INT) or line-lock mode (LL).  
**INT:** Sets to internal 2:1 interlace.  
**LL:** Sets to Line-lock mode.
- Back Light Compensation Mode Selector (BLC ON, OFF)**  
Lets you select the mode according to the position of the object and light conditions on the screen.  
**ON:** Select this mode when a strong light such as a spotlight is in the background.  
**OFF:** Normal picture.
- Detail/Aperture Level Selector (SHARP, SOFT)**  
The detail/aperture level can be selected with this selector. Set it to the desired position while observing the picture on the monitor.  
**SHARP:** Normal position.  
**SOFT:** Select this position when a Quad System is connected to this camera.
- Automatic Light Control/Electronic Light Control Selector (ALC, ELC)**  
Lets you select the mode according to the lens type used.  
**ALC:** Select this mode when an auto iris lens (ALC lens) is used with this camera.  
**ELC:** Select this mode when a fixed iris lens or manual iris lens is used with this camera.
- Lens Drive Signal Selector (VIDEO, DC)**  
Lets you select the mode according to the type of auto iris lens drive signal to be supplied to the lens from the auto iris lens connector.  
**VIDEO:** Select this mode if you are using a auto iris lens that requires a video drive signal.  
**DC:** Select this mode if you are using a auto iris lens that requires a DC drive signal.

- ⑭ **Video Output Connector (VIDEO OUT)**  
This connector is for connecting with the VIDEO IN connector of the video monitor. Whenever the multiplexed vertical drive (VD2) signal is supplied to this connector, the camera synchronization mode is automatically set to Vertical Drive.

**Caution:** Connect to 12 V DC (10.5 V-16 V) or 24 V AC (19.5 V-28 V) class 2 power supply only. Make sure to connect the grounding lead to the GND terminal when the power is supplied from a 24 V AC power source.

## CONNECTIONS

### A. WV-CP240 (220 V - 240 V AC 50 Hz)

Connect the power cord to an electrical outlet of 220V - 240V AC 50Hz.

### B. WV-CP242 (12 V DC)

Connect the power cord to the DC 12V IN terminal on the rear panel of the WV-CP242.



12 V DC  
(10.5 V - 16 V)

Resistance of copper wire [at 20°C (68°F)]

Copper wire size (AWG)	#24 (0.22mm <sup>2</sup> )	#22 (0.33mm <sup>2</sup> )	#20 (0.52mm <sup>2</sup> )	#18 (0.83mm <sup>2</sup> )
Resistance Ω/m	0.078	0.050	0.03	0.018
Resistance Ω/ft	0.026	0.017	0.010	0.006

- Calculation of maximum cable length between camera and power supply :

$$10.5V DC \leq V_A - (R \times 0.42 \times L) \leq 16V DC$$

L : Cable length (m)

R : Resistance of copper wire (Ω/m)

V<sub>A</sub> : DC output voltage of power supply unit

$$L \text{ standard} = \frac{V_A - 12}{0.42 \times R} \quad (\text{meters})$$

$$L \text{ minimum} = \frac{V_A - 16}{0.42 \times R} \quad (\text{meters})$$

$$L \text{ maximum} = \frac{V_A - 10.5}{0.42 \times R} \quad (\text{meters})$$

### C. WV-CP244 (24 V AC 50 Hz)

Connect the power cable to the AC 24 V IN terminal on the rear panel of the WV-CP244.

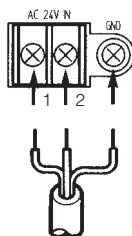

24 V AC, 50 Hz  
(19.5 V - 28 V)

Recommended wire gauge sizes for 24 V AC line

Copper wire size (AWG)	#24 (0.22mm <sup>2</sup> )	#22 (0.33mm <sup>2</sup> )	#20 (0.52mm <sup>2</sup> )	#18 (0.83mm <sup>2</sup> )
Length of cable (m)	95	150	255	425
Length of cable (Approx.) (ft)	314	495	842	1 403

## Video Cable

- It is recommended to use a monitor whose resolution is at least equal to that of the camera.
- The maximum extensible coaxial cable length between the camera and the monitor is shown below.

Type of coaxial cable	RG-59/U (3C-2V)	RG-6/U (5C-2V)	RG-11/U (7C-2V)	RG-15/U (10C-2V)
Recommended maximum cable length (m)	250	500	600	800
Recommended maximum cable length (ft)	825	1 650	1 980	2 640

## Installation of Auto Iris Lens Connector

Install the lens connector (YFE4191J100) when using a video drive ALC lens.

**The installation should be made by qualified service personnel or system installers.**

Cut the iris control cable at the edge of the lens connector to remove the existing lens connector and then remove the outer cable cover of the supplied connector as shown in the diagram.

The pin assignment of the lens connector is as follows:

- Pin 1: Power source; +9 V DC, 50 mA max.
- Pin 2: Not used
- Pin 3: Video signal; 0.7 V[p-p]/40 kΩ
- Pin 4: Shield, ground

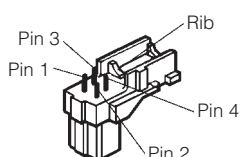

Solder the lens cable to the pins of the supplied connector.

## Mounting the Lens

### Caution:

Before you mount the lens, loosen the screw on the side of the camera, and rotate the flange-back adjusting ring clockwise until it stops. If the ring is not at the end, the inner lens or CCD image sensor may be damaged.

- Mount the lens by turning it clockwise on the lens mount of the camera.
- Connect the lens cable to the auto iris lens connector on the side of the camera.

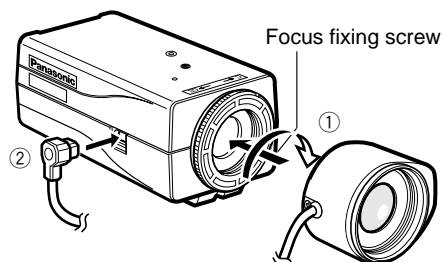

## Caution for Mounting the Lens

The lens mount should be a C-mount or CS-mount (1"-32UN) and the lens weight should be less than 450 g (0.99 lbs). If the lens is heavier, both the lens and camera should be secured by using the supporter.

The protrusion at the rear of the lens should be as shown below.

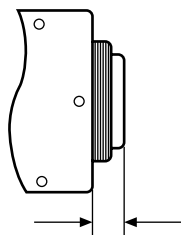

C-mount: Less than 13 mm (1/2")  
CS-mount: Less than 8 mm (5/16")

## FOCUS OR FLANGE-BACK ADJUSTMENT

The following adjustment should be made by qualified service personnel or system installers.

- Loosen the screw on the side of the camera.

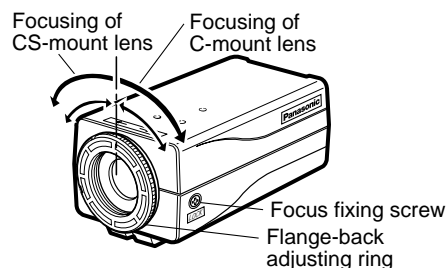

- Turn the flange-back adjusting ring to the desired position.

**Caution:** When the C-mount lens is mounted, do not rotate the ring counterclockwise by force after it stops. If the ring is rotated by force, the inner lens or CCD image sensor may be damaged.

- Tighten the screw on the side of the camera.

**Caution:** Tightening the screw by force will cause damage to the screw or deviation of focus.

## SPECIFICATIONS

Pick-up device:	752 (H) x 582 (V) pixels, interline transfer CCD
Scanning area:	4.89 (H) x 3.67 (V) mm (equivalent to scanning area of 1/3" pick-up tube)
Synchronization:	internal, line-locked or multiplexed vertical drive (VD2), selectable
Scanning system:	2 : 1 interlace
Scanning:	625 lines / 50 fields / 25 frames
Horizontal:	15.625 kHz
Vertical:	50 Hz
Horizontal resolution:	480 lines
Video output:	1.0 V[p-p] PAL composite 75 Ω / BNC connector
Signal-to-noise ratio:	50 dB (equivalent to AGC Off, weight On)
Electronic light control:	equivalent to continuous variable shutter speed between 1/50 s and 1/15 000 s
Minimum illumination:	0.6 lx (0.06 foot-candle) at F0.75 [equivalent to 2.0 lx (0.2 foot-candle) at F1.4] AGC On
Detail:	SHARP or SOFT, selectable
Lens mount:	C-mount or CS-mount, selectable
Ambient operating temperature:	-10°C - +50°C (14°F - 122°F)
Ambient operating humidity:	less than 90 %
Power source and power consumption:	WV-CP240: 220 V - 240 V AC 50 Hz, 3.4 W WV-CP242: 12 V DC, 270 mA WV-CP244: 24 V AC 50 Hz, 3.3 W
Dimensions (without lens):	67 mm (W) x 65 mm (H) x 123 mm (D) 2-5/8" (W) x 2-9/16" (H) x 4-13/16" (D)
Weights (without lens):	WV-CP240: 0.495 kg (1.09 lbs) WV-CP242: 0.33 kg (0.73 lbs) WV-CP244: 0.35 kg (0.77 lbs)

Weights and dimensions indicated are approximate. Specifications are subject to change without notice.

## STANDARD ACCESSORIES

Body cap	1 pc.
ALC lens connector (YFE4191J100)	1 pc.

## OPTIONAL ACCESSORIES

Lenses:	WV-LA2R8C3B, WV-LA4R5C3B, WV-LA9C3B, WV-LA210C3, WV-LA408C3, WV-LA908C3, WV-LZ61/10, WV-LZ62/2, WV-LZ62/8, WV-LF4R5C3A, WV-LF9C3A, WV-LFY3C3, WV-LFY45C3, WV-LFY9C3
---------	---

**Matsushita Electric Industrial Co., Ltd.**

Osaka, Japan

<http://www.panasonic.co.jp/global/>